

ERD SERIES

10x10 SIZE SEALED CONSTRUCTION ROTARY TYPE



ERD
1xxxx (Flat Type)



ERD
2xxxx (Shaft Type)

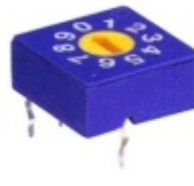

ERD
4XXXX (Flat Type)

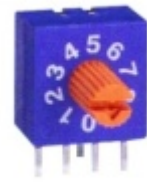

ERD
5xxxx (Shaft Type)

FEATURES

- Molded-in terminals and fully sealed construction.
- Standard 2.54mm pin spacing.
- All plastics UL 94V-0 grade fire retardant.
- Reliable contact and long-term stability.
- Binary decimal (8 or 10 positions) and hexadecimal (16 positions), real and complementary codes available.
- Pin-out compatible with most of current equivalents.
- Gold plated contacts to ensure low contact resistance.

SPECIFICATIONS

1. ELECTRICAL

Contact rating	
switching	25 mA, 24 VDC
non-switching	100 mA
Contact resistance	100 m Ω Max.
Insulation resistance	1000 M Ω Min. at 100 VDC
Dielectric strength	250 VAC Min. for 60 seconds

2. MECHANICAL

Temperature Rating	
operating	-25 $^{\circ}$ C to +70 $^{\circ}$ C
storage	-40 $^{\circ}$ C to +85 $^{\circ}$ C
Operation force	500 gf-cm Max.
Mechanical life	2000 steps per position
Vibration	10Hz-50Hz-10Hz for 6Hrs.
Solderability (for through hole type)	after flux 230 \pm 5 $^{\circ}$ C for 5 \pm 0.5 seconds, 95% coverage
Resistance to soldering heat (for through hole type)	260 \pm 5 $^{\circ}$ C for 5 \pm 1 seconds.
Reflow soldering heat for SMT type(reference only)	210 $^{\circ}$ C for 20 seconds or less, peak temperature 230 $^{\circ}$ C or less

PART NUMBERING SYSTEM

ERD 1 10 R S X
 +--- Blank:Standard
 Z:Lead-Free
 +--- Setting:
 S:Standard Type (Top Adjust Type)
 R:Right Angle Type with Rows Spacing
 2.54mm Side Adjust Type)
 F:Right Angle Type with Rows Spacing
 5.08mm (Side Adjust Type)
 M:Surface Mounting Type with
 Top Tape Sealed
 D:Surface Mounting Type with
 Top Tape Sealed in Tape & Reel Package
 +--- Code: R:Real
 C:Complement
 +--- Number of positions: 08,10,16
 +--- Rotor: 1:Flat Type (pin out 3:3)
 2:Shaft Type(pin out 3:3)
 4:Flat Type (pin out 1:4)
 5:Shaft Type(pin out 1:4)
 +--- Series name: ERD:Rotary Type Sealed Construction

CODE

PIN NO.	POSITION															
	0	1	2	3	4	5	6	7	8	9	A	B	C	D	E	F
1	●	●	●	●	●	●	●	●	●	●	●	●	●	●	●	●
2	●	●	●	●	●	●	●	●	●	●	●	●	●	●	●	●
4	●	●	●	●	●	●	●	●	●	●	●	●	●	●	●	●
8	●	●	●	●	●	●	●	●	●	●	●	●	●	●	●	●

●Real Code
 Rotor color: White (3:3), Yellow (1:4)
 ●Complement Code
 Rotor color: Red (3:3), Orange (1:4)

CONSTRUCTION

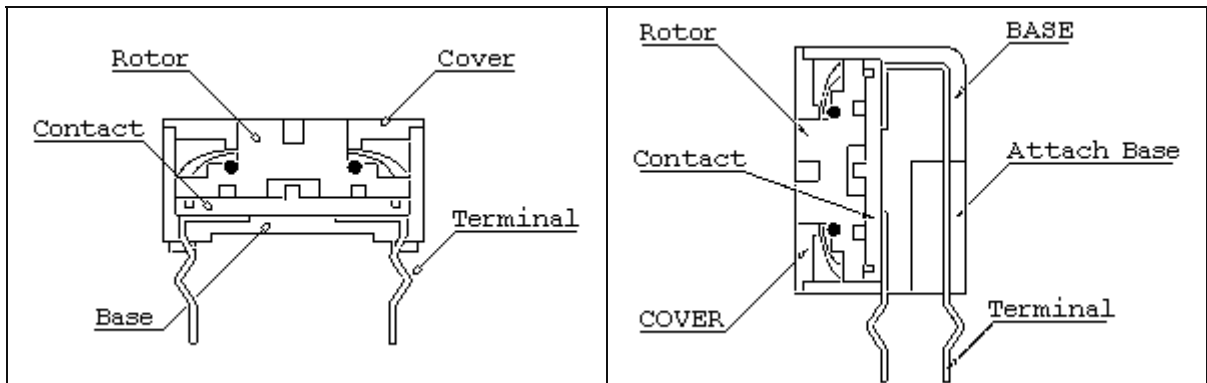

OPTIONS

- 1.Special marking available upon request.
- 2.Shaft Cover.
 - 418-80100(White 3:3)
 - 418-80200(Red 3:3)
 - 418-80300(Yellow 1:4)
 - 418-80400(Orange 1:4)

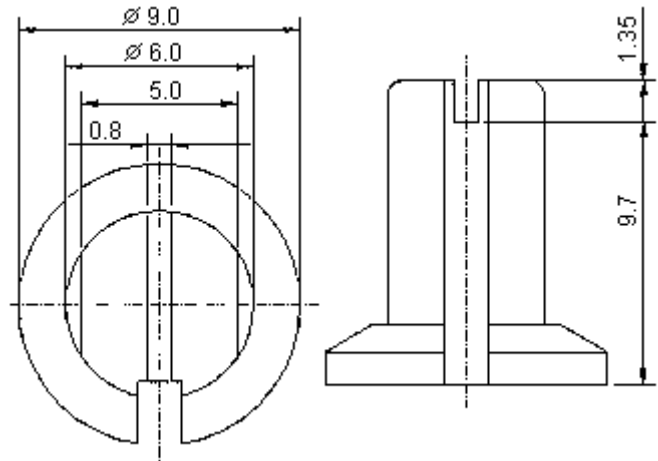
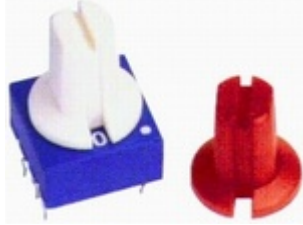

- 3.Tape & Reel Packaging (Per EIA STANDARD):

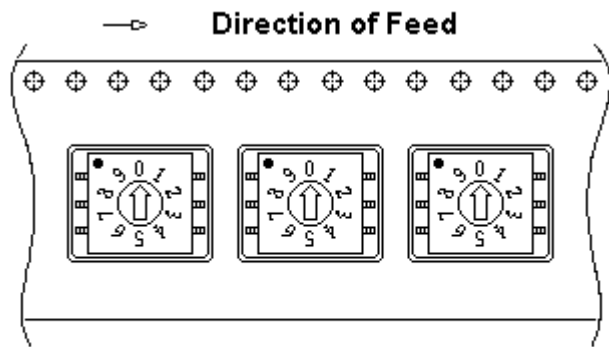
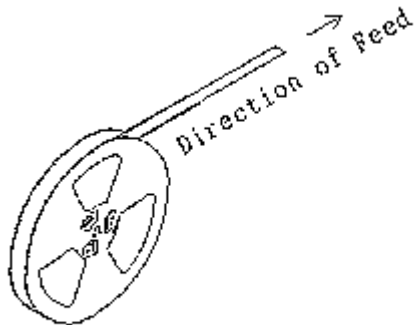

Each Reel contains 7000pcs switches with a 390mm minimum leader and a 160mm minimum trailer

INTRODUCTION to ECE ROTARY DIP SWITCH

SIZE	POSITIONS	CODE	PIN OUT	ROTOR	TYPE	PART NUMBER
10x10	8,10,16	REAL, COMPLEMENT	3:3	FLAT, SHAFT	STANDARD	ERD1xxxS, ERD2xxxS
					RIGHT ANGLE	ERD1xxxR/F, ERD2xxxR/F
				FLAT	SMT	ERD1xxxM
					SMT IN T&R	ERD1xxxD
			1:4	FLAT, SHAFT	STANDARD	ERD4xxxS, ERD5xxxS
					RIGHT ANGLE	ERD4xxxR/F, ERD5xxxR/F
				FLAT	SMT	ERD4xxxM
					SMT IN T&R	ERD4xxxD

DIMENSIONS AND CIRCUITRY UNIT:mm(inch) PIN OUT 3:3

<p>ERD1xxxS Flat Type STANDARD TYPE</p> <p>16 POSITIONS</p>	<p>ERD2xxxS Shaft Type</p> <p>16 POSITIONS</p>	<p>P.C.B. LAYOUT (TOP VIEW) ERDxxxxS</p>	
<p>ERD1xxxR Flat Type RIGHT ANGLE TYPE PITCH: 2.54mm</p> <p>16 POSITIONS</p>	<p>ERD2xxxR Flat Type</p> <p>16 POSITIONS</p>	<p>P.C.B. LAYOUT (TOP VIEW) ERDxxxxR</p>	
<p>ERD1xxxF Flat Type RIGHT ANGLE TYPE PITCH: 5.08mm</p> <p>16 POSITIONS</p>	<p>ERD2xxxF Flat Type</p> <p>16 POSITIONS</p>	<p>P.C.B. LAYOUT (TOP VIEW) ERDxxxxF</p>	
<p>ERD1xxxM Flat Type SMT TYPE (ONLY FLAT TYPE AVAILABLE)</p> <p>16 POSITIONS</p>			<p>P.C.B. LAYOUT (TOP VIEW) ERDxxxxM</p>

DIMENSIONS AND CIRCUITRY UNIT:mm(inch) PIN OUT 1:4

<p>ERD4xxxS Flat Type STANDARD TYPE</p> <p>16 POSITIONS</p>	<p>ERD5xxxS Shaft Type</p> <p>16 POSITIONS</p> <p style="text-align: center;">P.C.B. LAYOUT (TOP VIEW) ERDxxxxS</p>
<p>ERD4xxxR Shaft Type RIGHT ANGLE TYPE PITCH: 2.54mm</p> <p>16 POSITIONS</p>	<p>ERD5xxxR Shaft Type</p> <p>16 POSITIONS</p> <p style="text-align: center;">P.C.B. LAYOUT (TOP VIEW) ERDxxxxR</p>
<p>ERD4xxxF Flat Type RIGHT ANGLE TYPE PITCH: 5.08mm</p> <p>16 POSITIONS</p>	<p>ERD5xxxF Flat Type</p> <p>16 POSITIONS</p> <p style="text-align: center;">P.C.B. LAYOUT (TOP VIEW) ERDxxxxF</p>
<p>ERD4xxxM Flat Type SMT TYPE (ONLY FLAT TYPE AVAILABLE)</p> <p>16 POSITIONS</p> <p style="text-align: center;">P.C.B. LAYOUT (TOP VIEW) ERDxxxxM</p>	